



## ***User Manual***

Window Type Air Conditioner  
(Inverter Heat Pump)

RC-H7HR

RC-H9HR

RC-H12HR

RC-H18HR

RC-H24HR



A2L

Note:

Thank you for purchasing Rasonic window type air conditioner. Please read the user manual carefully before installation and well keep user manual for your later reference.



# CONTENTS

Thank you for choosing the Rasonic air conditioner. Our design is based on the best efficiency and the lowest noise operation and it can keep the room comfortable. Please read this user manual carefully before operating the unit and keep it for consultation.

## Structure mechanism and Installation

The Refrigerant	1
Specialist's Manual	2
Precautions	6
Function	7
Operating Condition	8
Power requirement	8
Installation	9
Notes for installation	12

## Operation procedure

Part identification	13
Air direction adjustment	13
Operation and introduction of remote controller	14
Remote control panel	18
Operation Tips	20

## Care and maintenance

CAUTION	21
Care and maintenance	22
Troubleshooting guide	24
After service	25
Safety operation of flammable refrigerant	26

## Explanation of Symbols



**DANGER**

Indicates a hazardous situation that, if not avoided, will result in death or serious injury.



**WARNING**

Indicates a hazardous situation that, if not avoided, could result in death or serious injury.



**CAUTION**

Indicates a hazardous situation that, if not avoided, may result in minor or moderate injury.

**NOTICE**

Indicates important but not hazard-related information, used to indicate risk of property damage.



Indicates a hazard that would be assigned a signal word WARNING or CAUTION.

## Exception Clauses

Manufacturer will bear no responsibilities when personal injury or property loss is caused by the following reasons.

1. Damage the product due to improper use or misuse of the product;
2. Alter, change, maintain or use the product with other equipment without abiding by the instruction manual of manufacturer;
3. After verification, the defect of product is directly caused by corrosive gas;
4. After verification, the defects are due to improper operation during transportation of product;
5. Operate, repair, maintain the unit without abiding by user manual or related regulations;
6. After verification, the problem or dispute is caused by the quality specification or performance of parts and components that produced by other manufacturers;
7. The damage is caused by natural calamities, bad using environment or force majeure.

- If it needs to install, move or maintain the air conditioner, please contact dealer or local service center to conduct it at first. Air conditioner must be installed, moved or maintained by appointed unit. Otherwise, it may cause serious damage or personal injury or death.
- When refrigerant leaks or requires discharge during installation, maintenance, or disassembly, it should be handled by certified professionals or otherwise in compliance with local laws and regulations.



A2L Appliance filled with mildly flammable refrigerant R32.



Before use the appliance, read the user manual first.



Before repair the appliance, read the service manual first.

## The Refrigerant

- To realize the function of the air conditioner unit, a special refrigerant circulates in the system. The used refrigerant is the fluoride R32, which is specially cleaned. The refrigerant is flammable and inodorous. Furthermore, it can lead to explosion under certain conditions. But the flammability of the refrigerant is very low. It can be ignited only by fire.
- Compared to common refrigerants, R32 is a nonpolluting refrigerant with no harm to the ozonosphere. The influence upon the greenhouse effect is also lower. R32 has got very good thermodynamic features which lead to a really high energy efficiency. The units therefore need a less filling.

### **WARNING:**

Do not use means to accelerate the defrosting process or to clean, other than those recommended by the manufacture. Should repair be necessary, contact your nearest authorized Service Centre. Installation work should be carried out by qualified personnel. Any repairs carried out by unqualified personnel may be dangerous. The appliance shall be stored in a room without continuously operating ignition sources. (for example: open flames, an operating gas appliance or an operating electric heater.) Do not pierce or burn.

Appliance filled with mildly flammable refrigerant R32. For repairs, strictly follow manufacturer's instructions only. Be aware that refrigerants might not contain an odour. Read specialist's manual.

The appliance is using mildly flammable refrigerant R32 and tested to comply with IEC 60335-2-40. There is no minimum room area requirement for the appliance. The lower limit of the installation height of this product is 0.75 meters.



A2L



# Specialist's Manual

- **Checks to the area**

Prior to beginning work on systems containing flammable refrigerants, safety checks are necessary to ensure that the risk of ignition is minimised. For repair to the refrigerating system, "Work procedure" to "No ignition sources" shall be completed prior to conducting work on the system.

- **Work procedure**

Work shall be undertaken under a controlled procedure so as to minimise the risk of a flammable gas or vapour being present while the work is being performed.

- **General work area**

All maintenance staff and others working in the local area shall be instructed on the nature of work being carried out. Work in confined spaces shall be avoided.

- **Checking for presence of refrigerant**

The area shall be checked with an appropriate refrigerant detector prior to and during work, to ensure the technician is aware of potentially toxic or flammable atmospheres. Ensure that the leak detection equipment being used is suitable for use with all applicable refrigerants, i.e. nonsparking, adequately sealed or intrinsically safe.

- **Presence of fire extinguisher**

If any hot work is to be conducted on the refrigerating equipment or any associated parts, appropriate fire extinguishing equipment shall be available to hand. Have a dry powder or CO<sub>2</sub> fire extinguisher adjacent to the charging area.

- **No ignition sources**

No person carrying out work in relation to a refrigerating system which involves exposing any pipe work shall use any sources of ignition in such a manner that it can lead to the risk of fire or explosion. All possible ignition sources, including cigarette smoking, should be kept sufficiently far away from the site of installation, repairing, removing and disposal, during which refrigerant can possibly be released to the surrounding space. Prior to work taking place, the area around the equipment is to be surveyed to make sure that there are no flammable hazards or ignition risks. "No Smoking" signs shall be displayed.

- **Ventilated area**

Ensure that the area is in the open or that it is adequately ventilated before breaking into the system or conducting any hot work. A degree of ventilation shall continue during the period that the work is carried out. The ventilation should safely

disperse any released refrigerant and preferably expel it externally into the atmosphere.

- **Checks to the refrigerating equipment**

Where electrical components are being changed, they shall be fit for the purpose and to the correct specification. At all times the manufacturer's maintenance and service guidelines shall be followed. If in doubt, consult the manufacturer's technical department for assistance.

The following checks shall be applied to installations using flammable refrigerants:

- the refrigerant charge is in accordance with the room size within which the refrigerant containing parts are installed;

- the ventilation machinery and outlets are operating adequately and are not obstructed;

- if an indirect refrigerating circuit is being used, the secondary circuit shall be checked for the presence of refrigerant;

- marking to the equipment continues to be visible and legible. Markings and signs that are illegible shall be corrected;

- refrigerating pipe or components are installed in a position where they are unlikely to be exposed to any substance which can corrode refrigerant containing components, unless the components are constructed of materials which are inherently resistant to being corroded or are suitably protected against being so corroded.

- **Checks to electrical devices**

Repair and maintenance to electrical components shall include initial safety checks and component inspection procedures. If a fault exists that could compromise safety, then no electrical supply shall be connected to the circuit until it is satisfactorily dealt with. If the fault cannot be corrected immediately but it is necessary to continue operation, an adequate temporary solution shall be used. This shall be reported to the owner of the equipment so all parties are advised.

Initial safety checks shall include:

- that capacitors are discharged: this shall be done in a safe manner to avoid possibility of sparking;

- that no live electrical components and wiring are exposed while charging, recovering or purging the system;

- that there is continuity of earth bonding.

- **Sealed electrical components**

Sealed electrical components shall not be repaired.

# Specialist's Manual

- **Cabling**

Check that cabling will not be subject to wear, corrosion, excessive pressure, vibration, sharp edges or any other adverse environmental effects. The check shall also take into account the effects of aging or continual vibration from sources such as compressors or fans.

- **Repair to intrinsically safe components**

Do not apply any permanent inductive or capacitance loads to the circuit without ensuring that this will not exceed the permissible voltage and current permitted for the equipment in use. Intrinsically safe components are the only types that can be worked on while live in the presence of a flammable atmosphere. The test apparatus shall be at the correct rating.

Replace components only with parts specified by the manufacturer. Other parts may result in the ignition of refrigerant in the atmosphere from a leak.

- **Leak detection methods**

Leak detection fluids are suitable for use with most refrigerants but the use of detergents containing chlorine shall be avoided as the chlorine may react with the refrigerant and corrode the copper pipe-work.

- **Detection of flammable refrigerants**

Under no circumstances shall potential sources of ignition be used in the searching for or detection of refrigerant leaks. A halide torch (or any other detector using a naked flame) shall not be used. The following leak detection methods are deemed acceptable for all refrigerant systems.

Electronic leak detectors may be used to detect refrigerant leaks but, in the case of flammable refrigerants, the sensitivity can be inadequate, or can need re-calibration. (Detection equipment shall be calibrated in a refrigerant-free area.)

Ensure that the detector is not a potential source of ignition and is suitable for the refrigerant used. Leak detection equipment shall be set at a percentage of the LFL of the refrigerant and shall be calibrated to the refrigerant employed, and the appropriate percentage of gas (25 % maximum) is confirmed.

Leak detection fluids are also suitable for use with most refrigerants but the use of detergents containing chlorine shall be avoided as the chlorine can react with the refrigerant and corrode the copper pipe-work.

NOTE: Examples of leak detection methods are

- bubble method,

- fluorescent agent method.

If a leak is suspected, all naked flames shall be removed/extinguished.

If a leakage of refrigerant is found which requires brazing, all of the refrigerant shall be recovered from the system, or isolated (by means of shut-off valves) in a part of the system remote from the leak. Removal of refrigerant shall be according to the following Clause.

- **Refrigerant removal and circuit evacuation**

When breaking into the refrigerant circuit to make repairs – or for any other purpose – conventional procedures shall be used. However, for flammable refrigerants it is important that best practice is followed since flammability is a consideration. The following procedure shall be adhered to:

- safely remove refrigerant following local and national regulations;

- evacuate;

- purge the circuit with inert gas;

- evacuate;

- continuously flush with inert gas

- open the circuit by cutting or brazing.

The refrigerant charge shall be recovered into the correct recovery cylinders.

The manufacturer shall specify the inert gases that can be used. Compressed air or oxygen shall not be used for purging refrigerant systems.

NOTE An example of an inert gas is dry nitrogen.

Purging of the refrigerant circuit shall be achieved by breaking the vacuum in the system with inert gas and continuing to fill until the working pressure is achieved, then venting to atmosphere, and finally pulling down to a vacuum. This process shall be repeated until no refrigerant is within the system. The system shall be vented down to atmospheric pressure to enable work to take place.

Ensure that the outlet of the vacuum pump is not close to any potential ignition sources and that ventilation is available.

# Specialist's Manual

## • Charging procedures

In addition to conventional charging procedures, the following requirements shall be followed.

– Ensure that contamination of different refrigerants does not occur when using charging equipment. Hoses or lines shall be as short as possible to minimise the amount of refrigerant contained in them.

– Cylinders shall be kept in an appropriate position according to the instructions.

– Ensure that the refrigerating system is earthed prior to charging the system with refrigerant.

– Label the system when charging is complete (if not already labelled).

– Extreme care shall be taken not to overfill the refrigerating system.

Prior to recharging the system, it shall be pressure-tested with the appropriate purging gas. The system shall be leak-tested on completion of charging but prior to commissioning. A follow up leak test shall be carried out prior to leaving the site.

## • Decommissioning

Before carrying out this procedure, it is essential that the technician is completely familiar with the equipment and all its detail. It is recommended good practice that all refrigerants are recovered safely. Prior to the task being carried out, an oil and refrigerant sample shall be taken in case analysis is required prior to re-use of recovered refrigerant. It is essential that electrical power is available before the task is commenced.

1) Become familiar with the equipment and its operation.

2) Isolate system electrically.

3) Before attempting the procedure, ensure that:

a) mechanical handling equipment is available, if required, for handling refrigerant cylinders;

b) all personal protective equipment is available and being used correctly;

c) the recovery process is supervised at all times by a competent person;

d) recovery equipment and cylinders conform to

the appropriate standards.

4) Pump down refrigerant system, if possible.

5) If a vacuum is not possible, make a manifold so that refrigerant can be removed from various parts of the system.

6) Make sure that the cylinder is situated on the scales before recovery takes place.

7) Start the recovery machine and operate in accordance with instructions.

8) Do not overfill cylinders (no more than 80 % volume liquid charge).

9) Do not exceed the maximum working pressure of the cylinder, even temporarily.

10) When the cylinders have been filled correctly and the process completed, make sure that the cylinders and the equipment are removed from site promptly and all isolation valves on the equipment are closed off.

11) Recovered refrigerant shall not be charged into another refrigerating system unless it has been cleaned and checked.

## • Labelling

Equipment shall be labelled stating that it has been de-commissioned and emptied of refrigerant. The label shall be dated and signed. For appliances containing flammable refrigerants, ensure that there are labels on the equipment stating the equipment contains flammable refrigerant.

## • Recovery

When removing refrigerant from a system, either for servicing or decommissioning, it is required to follow good practice so that all refrigerants are removed safely.

When transferring refrigerant into cylinders, ensure that only appropriate refrigerant recovery cylinders are employed. Ensure that the correct number of cylinders for holding the total system charge is available. All cylinders to be used are designated for the recovered refrigerant and labelled for that refrigerant (i.e. special cylinders for the recovery of refrigerant). Cylinders shall be complete with pressure-relief valve and associated shut-off valves in good working order. Empty recovery cylinders are evacuated and, if possible, cooled before recovery occurs.

The recovery equipment shall be in good working order with a set of instructions concerning the equipment that is at hand and shall be suitable for the recovery of the flammable refrigerant. Consult manufacturer if in doubt. In addition, a set of calibrated weighing scales shall be available and in good working order. Hoses shall be complete with leak-free disconnect couplings and in good condition.

# ● Specialist's Manual

Before using the refrigerant recovery machine, check that it is in satisfactory working condition, has been properly maintained, and that all relevant electrical components are sealed to prevent ignition during refrigerant release. If in doubt, consult the manufacturer.

The recovered refrigerant shall be processed according to local legislation in the correct recovery cylinder, and the relevant waste transfer note arranged. Do not mix refrigerants in recovery units and especially not in cylinders.

If compressors or compressor oils are to be removed, ensure that they have been evacuated to an acceptable level to make certain that flammable refrigerant does not remain within the lubricant. The compressor body shall not be heated by an open flame or other ignition sources to accelerate this process. Draining of oil from a system shall be carried out safely.

- General

That the installation of pipe-work shall be kept to a minimum.

That pipe-work shall be securely mounted and guarded from physical damage.

That compliance with national gas regulations shall be observed.

That connections between parts of the refrigerating system shall be accessible for maintenance purposes.

## Precautions

### WARNING

The air conditioner should be installed in accordance with national wiring regulations. Air Conditioner should be properly grounded. Incorrect grounding may cause electric shock.

- This appliance can be used by children aged from 8 years and above and persons with reduced physical, sensory or mental capabilities or lack of experience and knowledge if they have been given supervision or instruction concerning use of the appliance in a safe way and understand the hazards involved.
- Children shall not play with the appliance.
- Cleaning and user maintenance shall not be made by children without supervision.
- Do not connect air conditioner to multi-purpose socket. Otherwise, it may cause fire hazard.
- Do install the air switch. If not, it may cause malfunction.
- Do not spill water on the remote controller, otherwise the remote controller may be broken.
- Do not spray water on air conditioner. It may cause electric shock or malfunction.
- Do not extend fingers or objects into air inlet or air outlet. It may cause personal injury or damage.
- Do not step on air conditioner, or put heavy objects. It may cause damage or personal injury.
- Do not block air outlet or air inlet. It may cause malfunction.
- Do disconnect power supply when cleaning air conditioner. Otherwise, it may cause electric shock.
- Do not repair air conditioner by yourself. It may cause electric shock or damage. Contact dealer when you need to repair air conditioner.
- Maintenance must be performed by qualified professionals. Otherwise, it may cause injury or damage.
- The appliance is not to be used by persons (including children) with reduced physical, sensory or mental capabilities, or lack of experience and knowledge, unless they have been given supervision or instruction.
- Children being supervised not to play with the appliance.
- Precautions shall be taken to avoid excessive vibration or pulsation to refrigerating piping.

Install the devices for short-circuit protection and electrical leakage protection when installing the air conditioner.

According to the local safety regulations, use qualified power supply circuit and circuit breakers.

### Working temperature range

※ Operating Temperature Range		
	Indoor side DB/WB(°C)	Outdoor side DB/WB(°C)
Maximum cooling	32/23	43/-
Maximum heating	27/-	24/18

The operating temperature range (outdoor temperature) for cooling only unit is 18°C - 43°C; for heat pump unit is -1°C - 43°C.

# ● Function

## Introduction

Window type room air conditioners can regulate the room temperature and dry the room. It is convenient for your work, study and life. It can be widely used in residence, shop, hotel, office, library and laboratory, and so on.

### Cooling in summer

In hot summer, air conditioner can cool down the room air by transferring heat out.

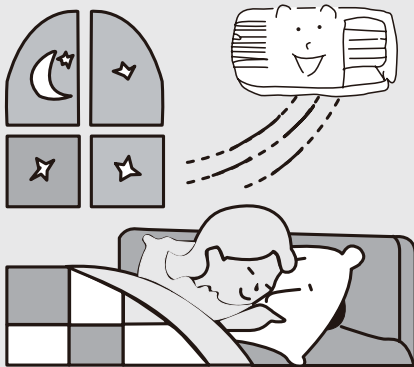

### Dehumidifying in rainy or humid season

Without reducing the room temp., air conditioner can dehumidify and make the room air dry and comfortable.



### Heating in winter (Only for heat unit)

In cold winter, air conditioner can heat up room air.



## ● Operating Condition

- Operate air conditioner in the correct conditions as following.

COOL mode operation	DRY mode operation
<p>Outdoor temperature should be in range of 18 °C to 43 °C, otherwise it is possible for air conditioner to breakdown.</p> <p>Room humidity should be lower than 90%. Otherwise, it is possible for air conditioner to dew at air conditioner surface and even drop water af-ter running for so much time. But this is normal.</p>	<p>Outdoor temperature should be in range of 18 °C to 43 °C, otherwise it is possible for air conditioner to breakdown.</p>

## Power requirement



- \* The electric components will be damaged when the voltage is too high. If the voltage is too low, the compressor will vibrate violently to damage the refrigerant system and easily cause the compressor and electric components not work.

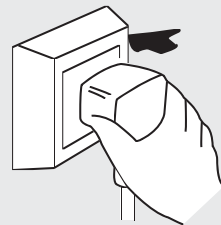

- The ground must be connected.
- \* Special socket must be used. Furthermore, the socket and wiring must conform to the wiring regulations. And the earthing method must be reliable.
- \* In fixed circuit, there must be electricity leakage protection switch of enough power capacity and air switch with enough space.



**Earth wire** To ensure the reliable earthing, do not connect earth wire to the following places:

Water pipe

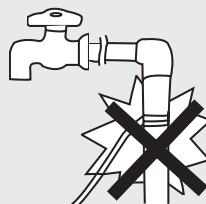

# ● Installation

## Installation precaution:

Window type air conditioner is so valuable and the improper installation of it will cause a lot of damage! Please associate the professional technician to install the unit and do not install it by yourself. Otherwise, we are not responsible for the damage like this.



## Location:

- The condensation water must be drained away conveniently.
- Install air conditioner unit far away from TV set or radio etc. to avoid disturbing video or voice.
- In salt and coastal area or place where is near thermal springs and polluted by sulphurous gas, or other special areas, please contact the seller before use.
- Avoid a place where is possible for inflammable gas to leak out.
- Avoid other heat sources or direct sun light.
- Avoid a place where is easy for children to touch.
- Don't use the unit in the immediate surroundings of a laundry, a bath, a shower or a swimming pool.
- For window type air conditioner with remote control, install in a location where is strong electromagnetic disturbance, you should contact the seller in advance to avoid the malfunction in use.

## How to install:

- Choose a location where there are no any obstacle surrounding the unit, and the plug is accessible.
- Prepare the installation hole slightly bigger than unit size.
- Choose the installation space according to the following diagram.

The distance between the air conditioner and the around obstacles should meet the requirement as below: over 300mm (upper side), over 500mm (left side), over 500mm (right side), over 1500mm (front side) and over 500mm (rear side).

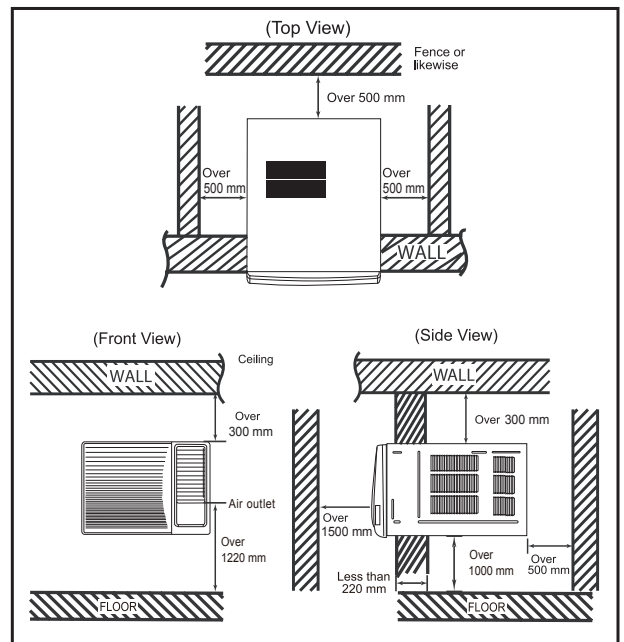

## Installation procedure:

- 1) Remove the sticker from the front panel.
- 2) Put the unit into the installation hole.
  - When installing the unit, it should be slanted down to the back to ensure that condensate can be easily drained. (Slant between 6-10mm.)(Shown at right figure.)
  - The installation place should be strong enough to avoid the enlargement of noise or vibration.
- 3) Fill up sews in the cabinet with sponge or foam.

## Installation assistance:

- Use iron support  
The installation hole should be strong enough to support the air conditioner. If it cannot, iron support has to be used outdoors.  
Iron support should be fixed on the building (Shown at right figure.)
- Use sunshade board  
Air conditioner should avoid anything to be dropped into it and avoid direct sunshine. If there is no cover on it, you should install the sunshade board. When installing the sunshade board, don't let it block the air inlet at the side grille.

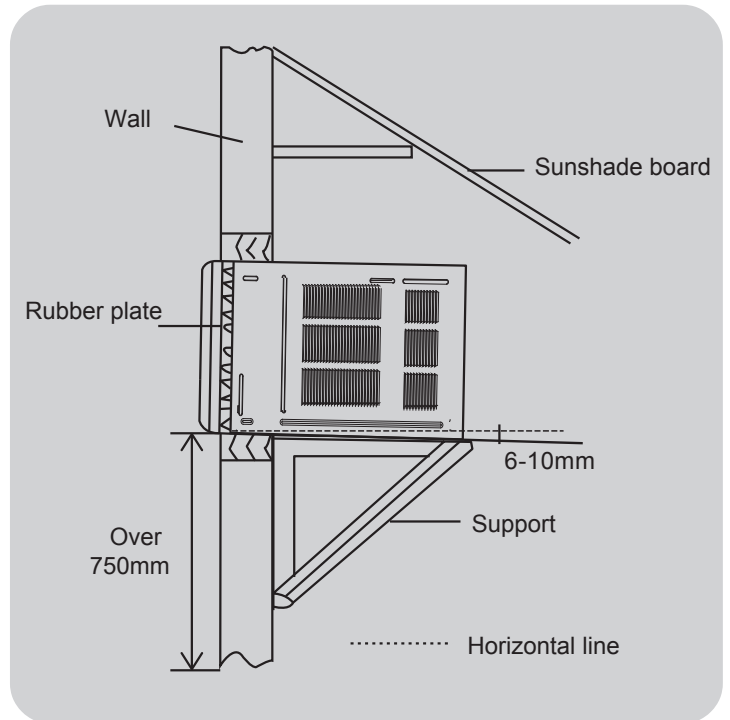

## Drain water for one style:

To get the maximum cooling efficiency, the air conditioner is designed to splash the condensate on the condenser coil.

If the splashing sound annoys you, you can provide an outside drain by using the following procedure, which may however cause a small loss of performance.

1. There is a drainage outlet at the back of the unit.
2. Remove cover from the drainage outlet, and then connect drainage joint to it with screw.
3. Connect the drain hose to the outlet.

Note:

Drain hose or tubing can be purchased locally to satisfy your particular needs.

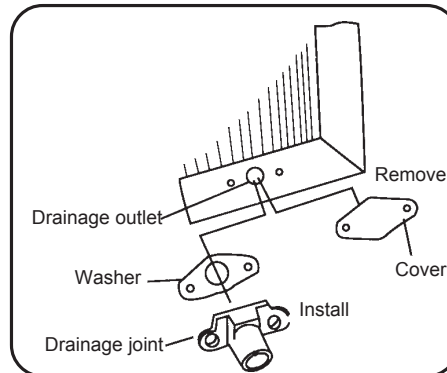

## Drain water for another style :

To get the maximum cooling efficiency, the air conditioner is designed to splash the condensation water on the condenser coil.

So if you want to increase the performance, you can install the rubber plug to the body base plate by using the 1, 2, 5 steps of the following procedure in summer. In winter or the splashing sound annoys you, you must remove the rubber plug and install an outside drain according to the following procedure:

1. Slide out the chassis from the cabinet.
2. Remove the rubber plug from the body base plate.
3. Install the drain pan to the corner of the cabinet with 2 screws.
4. Connect the drain hose to the outlet on the drain pan bottom.
5. Slide the chassis into its original place in the cabinet.

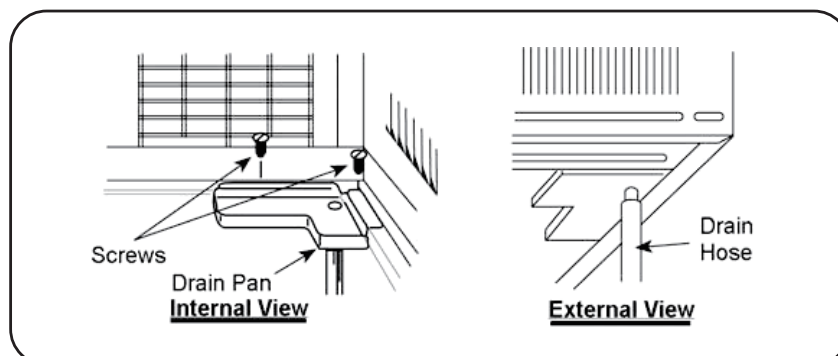

Note:

- Drain pan and drain hose must be installed before using reverse cycle models.
- Drain hose or tubing can be purchased locally to satisfy your particular needs.
- The diagram of drainage methods in the instruction manual is for reference only. Please refer to the actual product.

## ● Notes for installation

### Remove

Before removing air conditioner to the other place, you should contact the seller firstly.  
Then it must be done under the direction of the professional technician. In addition, the charge of this must be paid.

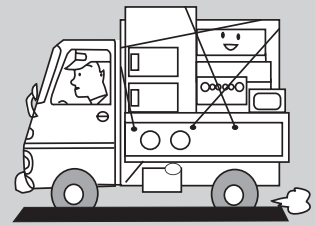

### Noise

- Install in a location where is firm enough to avoid the enlargement of noise and vibration.
- Do not put anything in front of the outlet of the unit to avoid increasing noise.
- Be sure that hot air or noise will not inconvenience neighbors.
- Please contact the seller as soon as there is strange noise during operation. Please use the safety support.



### Electric wiring

- Must connect with ground reliably.
- The exclusive circuit must be used. But removable socket cannot be used because poor contact of it can cause over heat or fire.
- Do not pull the power cord strongly.
- In fixed circuit, there must be electricity leakage protection switch and leakage current is less than 30mA.
- Air switch (thermal-magnetic breaker) should be installed in the circuit and its capacity is 10A(07K、09K、12K) / 16A (18K、24K).
- Connecting method between air conditioners and power cord and interconnecting method of each individual element with one another should accord with wiring diagram on the unit.
- The air conditioner should be installed in accordance with national wiring regulations.
- An all-pole disconnection switch having a contact separation of at least 3mm in all poles should be connected in fixed wiring.
- If the supply cord is damaged, it must be replaced by the manufacturer or your dealer or a qualified person to avoid a hazard.
- All the electrical work must be done according to the local wiring regulations.

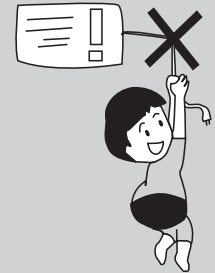

## ● Part identification

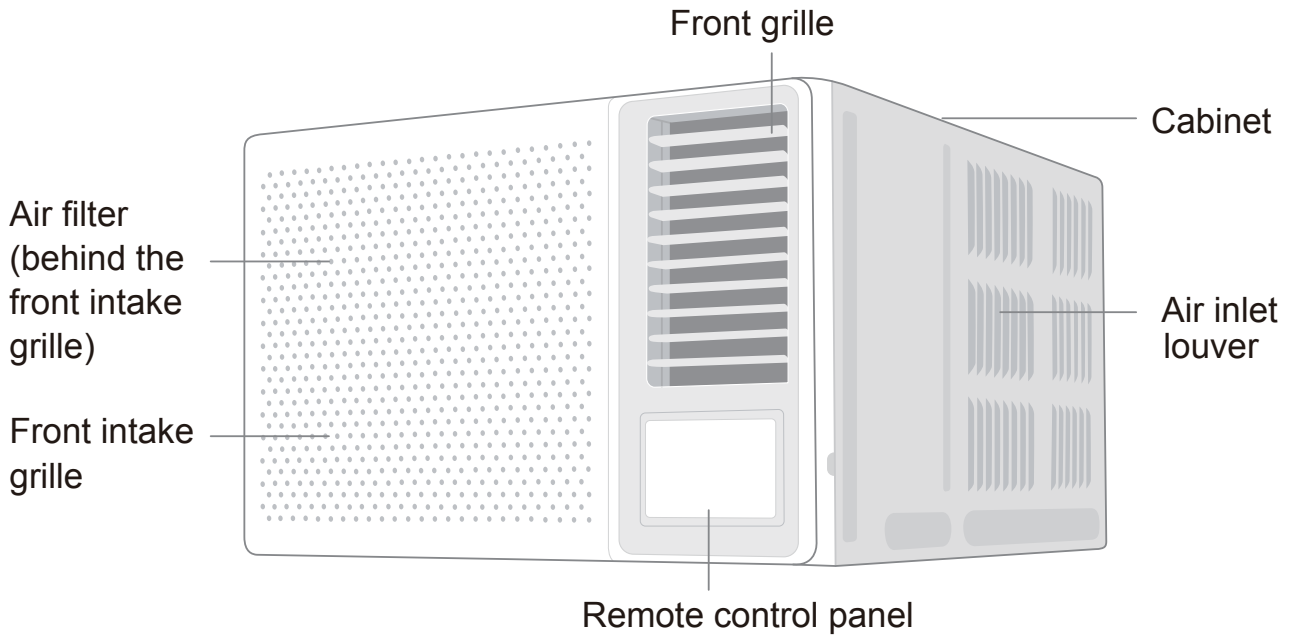

**NOTE:** Panel outlook picture, just for reference, please take the real unit as standard.

### Air direction adjustment

#### Vertical airflow direction vane

(Airflow direction adjustment up and down)

The vertical airflow direction vane is controlled by positioning the vane to discharge the air upwards, downwards or straight out.

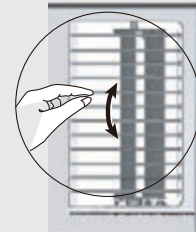

#### Installation method for 3-in-1 air filter

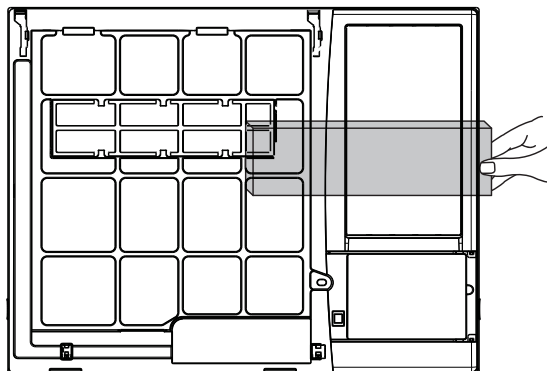

## ● Operation and introduction of remote controller

### ■ Buttons on remote controller

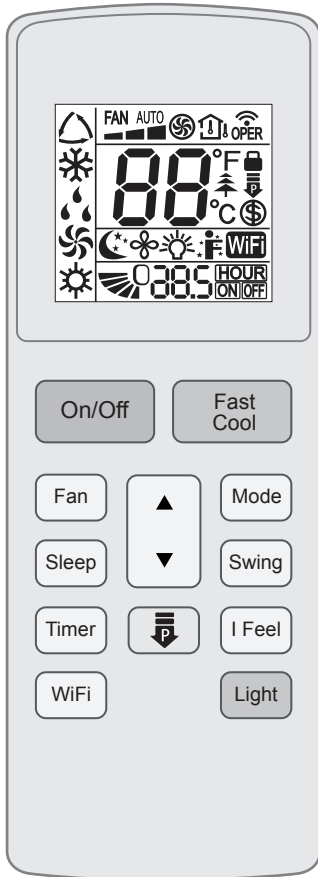

### ■ Introduction for icons on display screen

	I feel
	Set fan speed
	Fast Cool mode
	Send signal
	Auto mode
	Cool mode
	Dry mode
	Fan mode
	Heat mode
	Sleep mode
	8°C heating function(Not applicabe)
	Health mode(Not applicable)
	Power limiting operation
	X-FAN function(Not applicable)
	Set temp.
	Indoor ambient temp. (Fan mode only)
	Outdoor ambient temp. (Not applicable)
	Set temperature
	WiFi function(Not applicable)
	Set time
	TIMER ON / TIMER OFF
	Light
	Up & down swing(Not applicable)
	Child lock

## Introduction for buttons on remote controller

### NOTE

- This is a general use remote controller. It could be used for the air conditioner with multifunction. For the functions which the model does not have, if press the corresponding button on the remote controller, the unit will keep the original running status.
- After putting through the power, the air conditioner will give out a sound. After that, you can operate the air conditioner by using remote controller.
- Under on status, pressing the button on the remote controller, the signal icon "📶" on the display of remote controller will blink once and the air conditioner will give out a "di" sound, which means the signal has been sent to the air conditioner.

On/Off button

Press this button to turn on the unit. Press this button again to turn off the unit.

Fast Cool button

Press this button under cooling mode can select 25°C fast cooling mode, 16°C fast cooling mode and normal cooling mode circularly.





Once it enters into fast cooling mode, the fan speed is auto fan and the set temperature is 25°C or 16°C. At this time, the set temperature flashes to display for 5s. In the flashing period, press "▲" or "▼" button to adjust the set temperature. Press "FAN" button to adjust the fan speed. If the set temperature and the fan speed have not been adjusted during that time, the remote controller and the indoor unit will operate under current set temperature and fan speed for 20 minutes. 20 minutes later, the set temperature and the fan speed for the remote controller and the indoor unit will turn to the status before quick cooling.

### NOTE

- If the set temperature and the fan speed have been adjusted during the operation under fast cooling mode, the unit will exit from the fast cooling mode. Then the indoor unit operates continuously under the adjusted status.
- Fast cooling function is only applicable for some models. If this function is unavailable for this indoor unit, 20 minutes later, the remote controller will turn back to the status before fast cooling. Indoor unit operates continuously according to current status. At this

time, status of indoor unit and the display status on the remote controller may be different.

Fan button

This button is used for setting Fan Speed in the sequence that goes from AUTO, , ,  to  then back to AUTO.

### NOTE

-  is unavailable to setting under FAN mode.
- Fan speed under dry mode is low speed.
- X-FAN function is not available.

▲ ▼ button

Press ▲ / ▼ button to increase / decrease set temperature. In AUTO mode, set temperature is not adjustable.

When setting Timer On or Timer Off, press "▲" or "▼" button to adjust the time.

Mode button

Each time you press this button, a mode is selected in a sequence that goes from AUTO, COOL, DRY, FAN, and HEAT, as the following:



### Sleep button

Under Cool, Heat mode, press this button to turn on Sleep function.  
Press this button again to cancel Sleep function.  
Under Fan, Dry and Auto modes, this function is unavailable.

### Swing button

Press this button to turn "ON" & "OFF" swing.

### Timer button

- Under ON status, press this button to set timer OFF; Under OFF status, press this button to set timer ON.
- Press this button once and the characters of HOUR ON (OFF) will flash to be displayed. Meanwhile, press "▲" button or "▼" button to adjust timer setting (time will change quickly if holding "▲" or "▼" button). Time setting range is 0.5 - 24 hours. Press this button again to confirm timer setting and the characters of HOUR ON (OFF) will stop flashing.

If the characters are flashing but you have not press timer button, timer setting status will be quit after 5s. If timer is confirmed, press this button again to cancel timer.

### I Feel button

Press this button to start I FEEL function and "⌘" will be displayed on the remote controller. After this function is set, the remote controller will send the detected ambient temperature to the controller and the unit will automatically adjust the indoor temperature according to the detected temperature. Press this button again to close I FEEL function and "⌘" will disappear.

Please put the remote controller near user when this function is set. Do not put the remote controller near the object of high temperature or low temperature in order to avoid detecting inaccurate ambient temperature. When I FEEL function is turned on, the remote controller should be put within the area where indoor unit can receive the signal sent by the remote controller.

### Power Limiting button

Power limiting function is for limiting power of the whole unit. Press this button, the remote controller will circularly display as the following:



- Maximum power limited under the Power Limiting mode is lower than that of Normal mode.
- If you want to cancel the power limiting function, press the Power Limiting button until the icon in remote controller is not displayed.
- When the remote controller is turned off, power limiting function is cancelled. If you want to activate the function, please repress this button.
- If the current power is lower than the maximum power of Normal mode, then the power will not be limited after entering into such mode.
- For the model with one outdoor unit and two indoor units, if any one of indoor units enters into power limiting function, the outdoor unit will enter into the set limiting power mode of indoor unit; when two indoor units enter into power limiting mode, then the power of outdoor unit will be limited according to the lower power of the two indoor units.
- This button is only available for the model with such function.

#### NOTE

- Above function can be used at any time. However, when the room temperature is too high and the user feels very hot, this function is suggested not to be used immediately. You are suggested to use this function when room temperature is decreased a little. In this case, the comfort can be ensured.



### WiFi button (not applicable)

### Light button

Press this button to turn on the display's light and press this button again to turn off the display's light.

## Function introduction for combination buttons

Combination of "▲" and "▼" buttons:  
About child lock

Press "▲" and "▼" buttons simultaneously 3s to lock or unlock the keypad. If the remote controller is locked,  is displayed. In this case, pressing any button,  blinks three times.

Combination of "Mode" and "▼" buttons:  
About switch between Fahrenheit and centigrade

At unit OFF, press "Mode" and "▼" buttons simultaneously to switch between °C and °F.

Combination of "Mode" and "Sleep" button:  
About 8°C Heating Function(Not Applicable)

Press "Mode" and "Sleep" simultaneously in HEAT mode to start 8°C Heating Function. The screen on the remote controller displays "8°C" and a selected temperature of "8°C". (46°F if Fahrenheit is adopted). Repeat the operation to quit the function.

### NOTE

- This function is only available for some models.

### Health function(Not Applicable)

Under ON status, press "Fan" and "▼" buttons at the same time to turn on or off the health function.

### NOTE

- This function is only available for some models.

## Replacement of batteries in remote controller

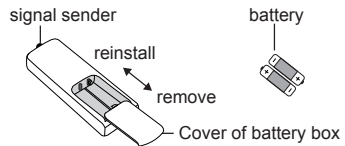

1. Press the back side of remote controller marked with "ON/OFF", as shown in the fig, and then push out the cover of battery box along the arrow direction.
2. Replace two 7# (AAA 1.5V) dry batteries, and make sure the position of "+" polar and "-" polar are correct.
3. Reinstall the cover of battery box.

### NOTICE

- During operation, point the remote control signal sender at the receiving window on indoor unit.
- The distance between signal sender and receiving window should be no more than 8m, and there should be no obstacles between them.
- Signal may be interfered easily in the room where there is fluorescent lamp or wireless telephone; remote controller should be close to indoor unit during operation.
- Replace new batteries of the same model when replacement is required.
- When you do not use remote controller for a long time, please take out the batteries.
- If the display on remote controller is fuzzy or there is no display, please replace batteries.

## Remote control panel

### Note:

- If wireless remote controller is lost, you can use the remote control panel and operate manually.
- The schematic diagram in the user manual is only for reference. Please refer to the actual product.

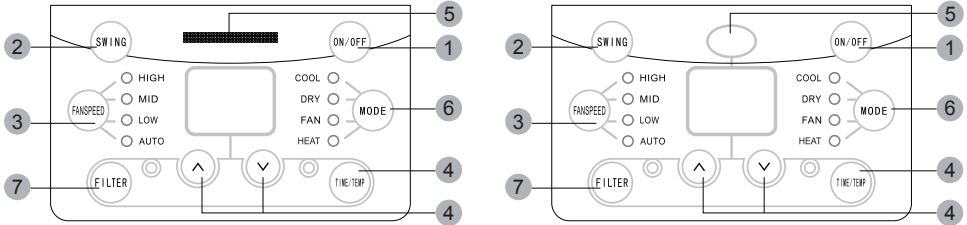

### 1 ON/OFF BUTTON

Operation starts when pressing this button, and stops when pressing this button again.

### 2 SWING BUTTON

Activate the automatic air swing function.

### 3 FAN SPEED BUTTON

Select the fan speed LOW, MID, HIGH and AUTO in sequence.

### 4 TIME/TEMP BUTTON

Press the  $\wedge$  button to increase the set (operating) temperature of the unit. Press the  $\nabla$  button to decrease the set (operating) temperature of the unit. The temperature setting range is from 16 - 30°C. Press the  $\wedge$  button also to increase the selected time in 0.5 hour increments, and press the  $\nabla$  button to decrease the selected time in 0.5 hour decrements. The time setting range is from 0 - 10 hours. Press the  $\wedge$  button also to increase the selected time in 1 hour increments, and press the  $\nabla$  button to decrease the selected time in 1 hour decrements. The time setting range is from 10 - 24 hours.

---

5 SIGNAL RECEIVER

6 MODE BUTTON

Select the operation mode, COOL, DRY, FAN, HEAT.

7 FILTER BUTTON

This feature is a reminder to clean the Air Filter (See Care and Cleaning) for more efficient operation and cooling. The LED (light) will illuminate after 250 hours of operation. To reset after cleaning the filter, press the "FILTER" button and the light will go off. Before the LED(light) illuminate, press the "FILTER" button until after 3 seconds, the accumulated time of operation will be canceled.

## ● Operation Tips

### Operation for comfort and economy

Do not overcool the room temperature. This is not good for health and wastes electricity.

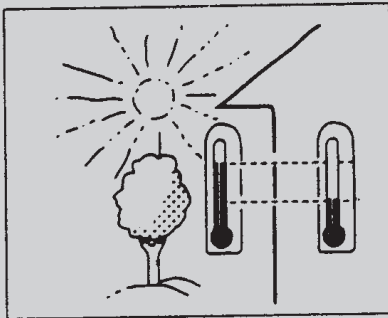

Keep blind or curtains closed. Do not let sunshine enter the room directly when the air conditioner is in operation.

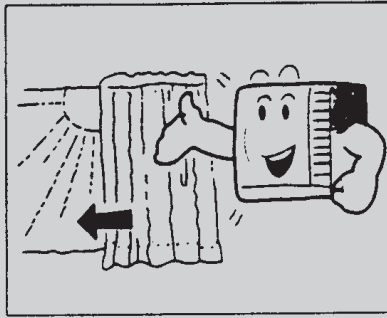

Keep the room temperature uniform. Adjust the vertical and horizontal airflow direction to ensure a uniform temperature in the room. Air cannot be discharged to the di-rection of air-in.

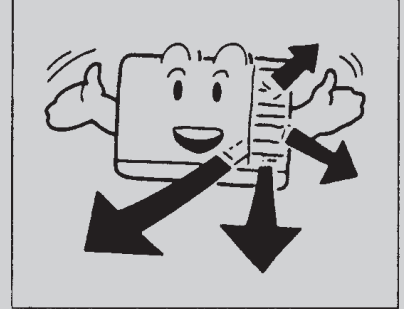

Make sure that the doors and windows are tightly closed. Avoid opening doors and windows as much as possible to reduce the cold air drain.

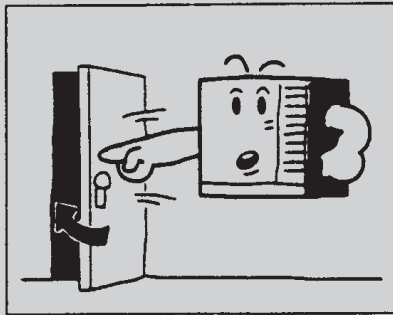

Clean the air filter regularly. Blockages in the air filter reduce dehumidifying effects. Clean the air filter at least once every two weeks.

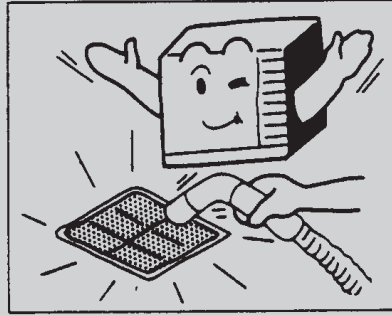

Ventilate the room occasionally. Since windows are kept closed, it is a good idea to open them and ventilate the room now and then. When starting the unit, curtains or windows should be closed to prevent the heat/cool leakage.

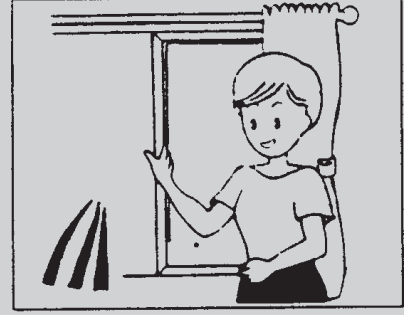

# ● CAUTION

## Operations for safety and health

- 1) The plug must be accessible after the appliance is positioned.
- 2) Do not use this appliance in the laundry.
- 3) If the power cord is damaged, it must be replaced by the manufacturer or its service agent in avoid of hazard.

- Do not pull out the power cord.
- Damage to the cord may result in serious electric shocks.

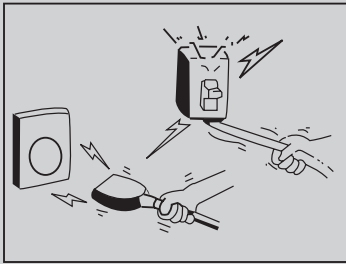

- Do not use the air conditioner for other purposes except for cooling the room.
- Do not use the air conditioner for other purposes such as drying clothes, preserving foods, or cultivating vegetables.



- Do not block the air intake and outlet vents
  - Do not insert sticks or other objects into these vents as it is dangerous to touch the electric components and the fan.
- This causes lowered performance and irregular operation.



Select the most appropriate temperature. Pay attention to adjust the temperature to suit the conditions. Rooms occupied by infants, the elderly, or the sick should be kept at an appropriate temperature.

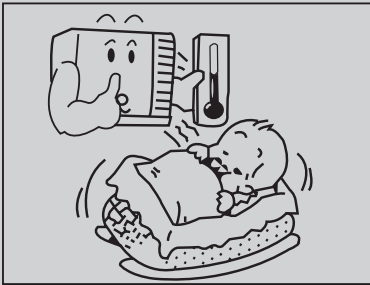

Do not use heating apparatuses in the vicinity. The air conditioner's plastic parts will melt if exposed to excessive heat.

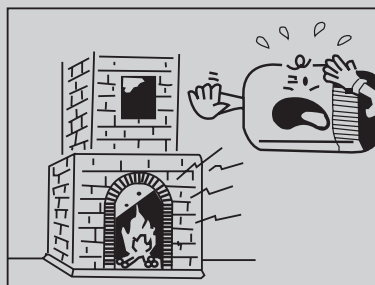

Avoid exposing the body directly to a continuous unidirectional air flow for long periods. This is not recommended for health reason.

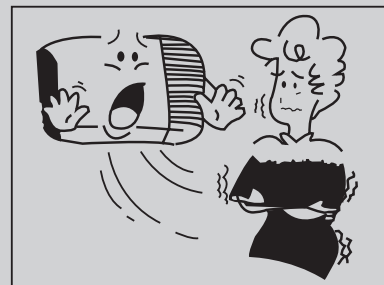

Always wait at least 3 minutes before switching the air conditioner on again after you have switched it off during cooling or heating.

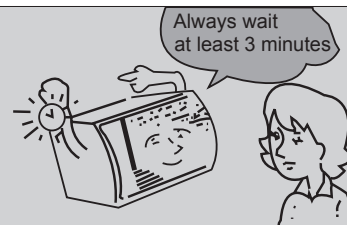

Please notice that the unit is filled with mildly flammable refrigerant R32. Inappropriate treatment of the unit involves the risk of severe damages of people and material. Details to this refrigerant are found in chapter "refrigerant".

The appliance is using mildly flammable refrigerant R32 and tested to comply with IEC 60335-2-40. There is no minimum room area requirement for the appliance.

## Care and maintenance

Always turn off the air conditioner and main power supply before cleaning to ensure safety.

### Cleaning unit

1. Cut power off before cleaning.

Plug out only after air conditioner stops at all.

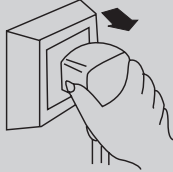

2. Use soft cloth when cleaning cabinet.

If the cabinet is very dirty, dip cloth into warm water below 40°C, dry the cloth and then rub off the dirt.



Dry the cloth by hands before cleaning.

3. Do not use gas, benzene, solvent, wash, chemical solvent, etc. for cleaning.



4. Do not splash water directly into the unit, in which there are micro-computer and circuit plate, they must not be drenched with water.



Accident could happen.

\* Check earth wire

Is it broken or loose?

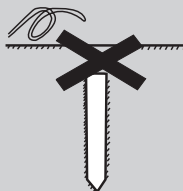

Air filter

The air filter behind the intake grille should be washed at least once every two weeks or as often as it needs cleaning.

How to clean the air filter:

1. To remove the air intake grille, grasp the tab on the filter and pull to take out.

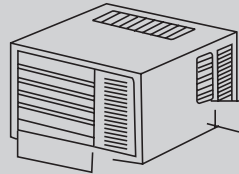

2. Vacuum the filter on the dusty side to remove light dust.

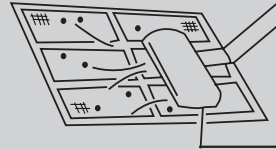

Vacuum cleaner

3. Wash the filter, cleaner side up under gently flowing water to wash out accumulated dust and lint.



4. If the filter is very dirty, use a mild household detergent in the wash water.



Let the filter dry thoroughly before reinstalling it. If necessary, please ask the professional personnel to clean it.

\* Check if air inlet and outlet of the unit are blocked or not.

Air block could result in bad efficiency.



## How to Remove and to Refit the Front Panel



### WARNING

In the work of this item, the authorized service personnel should work.

### Remove the front panel in the following manner

- ① Remove the fixing screw.  
There may also be screws on both edges of the front panel depending on the model type.

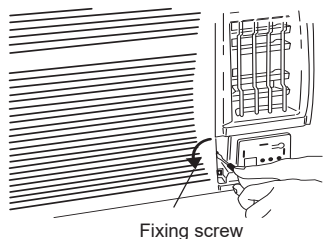

- ② Hold up the front panel with your hands to remove it.

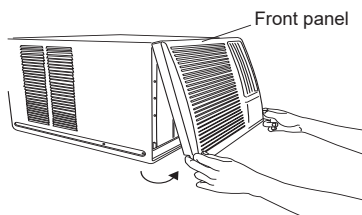

### Refit the front panel in the following manner

- ① Firstly the front panel is inset in two upper hooks and secondly it's inset in two lower hooks. The moving pole is inserted in a link plate surely.

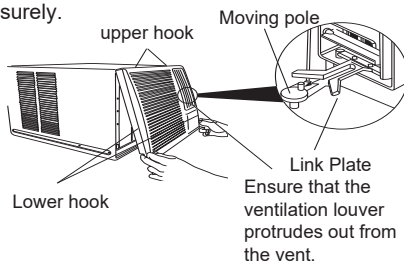

- ② Adjust the position so that the light of the unit's display could be seen from the front panel's display. After adjusting, fasten the screws. There may also be screws on both edges of the front panel depending on the model type.

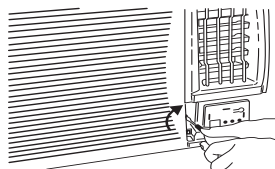

### When Not Using the Unit for Extended Periods (One Month or More)

Operate the unit on fan mode for about one-half day on a day with clear weather, to assure that the internal parts are dry.

When not using the unit for extended periods, disconnect the power plug for safety.

### Check the Power Cord



### WARNING

If the power cord is damaged, it must be replaced by the manufacturer, its service agent, or similarly qualified persons in order to avoid a hazard.





Check the power cord occasionally to confirm that it is not damaged by cuts or abrasions.

### Inspection and Repairs

Depending on the conditions of use, the internal parts of an air conditioner will become dirty after about two or three seasons of use, and performance may be affected. For this reason, regular professional maintenance is recommended. Consult authorized service personnel.

## ● Troubleshooting guide

Please check the following items before asking for repair, it saves your time and money.

Fault phenomenon	Trouble-shooting
<p>Air conditioner does not operate at all.</p> 	<ul style="list-style-type: none"> <li>* Is there a power failure?</li> <li>* Is the plug out?</li> <li>* Is power fuse or switch off ?</li> <li>* Whether the voltage is too high or too low?</li> </ul>
<p>Cool or heat efficiency is not good.</p> 	<ul style="list-style-type: none"> <li>* Is air inlet or outlet blocking?</li> <li>* Is there any other heat/cool source in room?</li> <li>* Are air filters dirty very much?</li> <li>* Is indoor fan speed set at LOW?</li> <li>* Maybe the room is too hot/cool when the unit is started.</li> </ul>
<p>Foggy air flows out.</p> 	<ul style="list-style-type: none"> <li>* At COOL mode operation, sometimes there is foggy air flowing out of the unit, this is because the room humid air has been cooling rapidly.</li> <li>* The unit is normal while the indoor outlet is sending out some odor, because the inlet air may be mixed with the smell of furniture and smoke.</li> </ul>
<p>The air conditioner operation is noisy.</p> 	<ul style="list-style-type: none"> <li>* For a noise that sounds like water flowing: This is the sound of refrigerant flowing inside the air conditioner unit.</li> <li>* For a noise that sounds like a shower: This is the sound of the dehumidifying water being processed inside the air conditioner unit.</li> </ul>
<p>It seems that condensation is leaking from air conditioner.</p>	<ul style="list-style-type: none"> <li>* Condensation occurs when the airflow from the air conditioner cools the warm room air.</li> </ul>
<p>Air conditioner does not operate for about 3 minutes when restart.</p>	<ul style="list-style-type: none"> <li>* This is to protection mechanism.</li> <li>* Wait about 3 minutes and operation will begin.</li> </ul>

Malfunction code	Solution
E5	Please contact Shun Hing Electric Service Centre Ltd.
E4	Please contact Shun Hing Electric Service Centre Ltd.
H3	Please contact Shun Hing Electric Service Centre Ltd.
H5	Please contact Shun Hing Electric Service Centre Ltd.
PL	Please contact Shun Hing Electric Service Centre Ltd.
PH	Please contact Shun Hing Electric Service Centre Ltd.
HC	Please contact Shun Hing Electric Service Centre Ltd.
Fo	Please contact Shun Hing Electric Service Centre Ltd.
F3	Please contact Shun Hing Electric Service Centre Ltd.
F4	Please contact Shun Hing Electric Service Centre Ltd.
F5	Please contact Shun Hing Electric Service Centre Ltd.
F0	Please contact Shun Hing Electric Service Centre Ltd.
E6	Please contact Shun Hing Electric Service Centre Ltd.
F1	Please contact Shun Hing Electric Service Centre Ltd.
F2	Please contact Shun Hing Electric Service Centre Ltd.
U7	Please contact Shun Hing Electric Service Centre Ltd.

Note: If there are other malfunction codes, please contact Shun Hing Electric Service Centre for service.

Immediately stop all operations and plug out, please contact Shun Hing Electric Service Centre Ltd. in the following situations.

- \*Operation starts or stops abnormally;
- \*Power fuse or switch often breaks;
- \*Carelessly splash water or something into air conditioner;
- \*Electrical lines are much hot or lines cover breaks;
- \*Other strange situations.



## ● Others

- The connection between AC and power cord or among other elements independently shall be subject to wiring diagram on the unit.
- Model and rated value of fuse shall be subject to screen print on corresponding controller or protective bushing.

## ● After service

- If your air conditioner has the questions of quality or anything else, please contact Shun Hing Electric Service Center Ltd.

## ● Safety operation of flammable refrigerant

### ● Qualification requirement for installation and maintenance man

1. All the work men who are engaging in the refrigeration system should bear the valid certification awarded by the authoritative organization and the qualification for dealing with the refrigeration system recognized by this industry. If it needs other technician to maintain and repair the appliance, they should be supervised by the person who bears the qualification for using the flammable refrigerant.
2. It can only be repaired by the method suggested by the equipment's manufacturer.

### ● Installation notes

1. The air conditioner is not allowed to use in a room that has running fire ( such as fire source, working coal gas ware, operating heater).
2. The appliance is using mildly flammable refrigerant R32 and tested to comply with IEC 60335-2-40. There is no minimum room area requirement for the appliance.  
The minimum room area is shown on the nameplate or following table.
3. Leak test is a must after installation.

## ● Maintenance notes

1. Check whether the maintenance area or the room area meet the requirement of the nameplate.
  - It's only allowed to be operated in the rooms that meet the requirement of the nameplate.
2. Check whether the maintenance area is well-ventilated.
  - The continuous ventilation status should be kept during the operation process.
3. Check whether there is fire source or potential fire source in the maintenance area.
4. Check whether the appliance mark is in good condition.
  - Replace the vague or damaged warning mark.
5. Electrical components that can arc or spark, which are not considered ignition sources shall only be replaced with parts specified by the appliance manufacturer. Replacement with other parts may result in the ignition of refrigerant in the event of a leak.

## ● Welding

1. If you should cut or weld the refrigerant system pipes in the process of maintaining, please follow the steps as below
  - a. Shut down the unit and cut power supply
  - b. eliminate the refrigerant
  - c. vacuuming
  - d. clean it with N<sub>2</sub> gas
  - e. cutting or welding
  - f. carry back to the service spot for welding
2. The refrigerant should be recycled into the specialized storage tank.
3. Make sure that there is not any naked flame near the outlet of the vacuum pump and it is well-ventilated.

## ● Filling the refrigerant

1. Use the refrigerant filling appliances specialized for R32. Make sure that different kinds of refrigerant will not contaminate with each other.
2. The refrigerant tank should be kept upright at the time of filling refrigerant.
3. Stick the label on the system after filling is finished (or have not finished).
4. Do not overfilling.
5. After filling is finished, please do the leakage detection before test running; another time of leak detection should be done when it is removed.

## ● Safety instructions for transportation and storage

1. Use the flammable gas detector to check before unload and open the container.
2. No fire source and smoking.
3. According to the local rules and laws.

## ● Special Avowal

- 1. The information above has been checked; our company reserves the hermeneutic power to any print errors or misunderstanding on the content.**
- 2. Any technology improvement will add into new user manual without any prior notices. The product appearance and color refer to the practical air conditioner.**
- 3. The e-copy of user manual can be sent by e-mail on requested, please call Shun Hing Electric Works & Engineering Co. Ltd. hotline at 2861 2767.**

## ● After sale service

Guarantee period state from the date of purchasing to one year. If the product is damaged under proper use, a free repair service is available. Please present the official invoice and the guarantee certificate with the sales point's chop / redemption center's chop for free maintenance. For enquiries, please contact Shun Hing Electric Service Centre Limited hotline at 2406 5666.

**Turn off the power and contact Shun Hing Electric Service Centre Ltd. as soon as any of the following events occur.**

- The circuit breaker frequently trips or the fuse blows regularly.
- If water or foreign objects have accidentally entered the air conditioner.
- If there is abnormal sound during operation.







**信興電工工程有限公司**

**SHUN HING ELECTRIC WORKS & ENGINEERING CO., LTD**

辦公室: 香港九龍尖沙咀東部麼地道 67 號半島中心 9 樓

OFFICE: 9/F, PENINSULA CENTRE, 67 MODY ROAD, TSIMSHATSUI  
EAST, KOWLOON, HONG KONG

電話 TEL: (852) 2861 2767

傳真 FAX: (852) 2865 6706

網址 WEBSITE: [www.shew.com.hk](http://www.shew.com.hk)

電郵 EMAIL: [shew@shunhinggroup.com](mailto:shew@shunhinggroup.com)

**保養及維修 MAINTENANCE AND REPAIR SERVICE**

**信興電器服務中心有限公司**

**SHUN HING ELECTRIC SERVICE CENTRE LTD.**

辦公室: 香港新界葵涌勝耀街2號信興中心11樓

OFFICE: 11TH FLOOR, SHUN HING CENTRE, 2 SHING YIU STREET, KWAI CHUNG, NEW  
TERRITORIES, HONG KONG

電話 TEL: (852) 2406 5666

傳真 FAX: (852) 2408 0316

網址 WEBSITE: [www.shesc.com](http://www.shesc.com)

**消耗品/附件銷售熱線 CONSUMABLES/ ACCESSORIES SALES HOTLINE**

電話 TEL: (852) 2406 5666

**客戶服務中心 CUSTOMER SERVICE CENTRES**

香港新界葵涌勝耀街2號信興中心1樓

1ST FLOOR, SHUN HING CENTRE, 2 SHING YIU STREET, KWAI CHUNG, NEW  
TERRITORIES, HONG KONG

電話 TEL: (852) 2406 5439

傳真 FAX: (852) 2408 1389

澳門慕拉士大馬路149號激成工業大廈(第一期)2樓F座

AVENIDA DE VENCESLAU DE MORAIS, NO. 149, 2 ANDAR-F, EDF. INDUSTRIAL  
KECK SENG (BLOCO 1), MACAU

電話 TEL: (853) 2836 2928

傳真 FAX: (853) 2833 6405

有關最新之客戶服務中心資訊, 請參閱信興服務中心網址: [www.shesc.com](http://www.shesc.com)或致電維修服務熱線查詢。

For the latest information of customer service centres, please visit [www.shesc.com](http://www.shesc.com) or call us at our hotline.

RC/HHR/0126



66139913950